

DOSSIER DE
PRESSE

PRATIQUER **LES ARTS**
PLASTIQUES A LA MAISON

*** En temps de confinement**



PRATIQUER LES ARTS PLASTIQUES A LA MAISON

* En temps de confinement

Le lundi 16 mars 2020, écoles, collèges et lycées sont restés fermés laissant des millions d'élèves chez eux par mesure de sécurité. C'est dans le contexte de la pandémie liée à la Covid-19 que le président de la République a pris cette mesure exceptionnelle. Un défi inédit se présente alors aux élèves, à leur famille et aux professeurs : la classe à la maison.

L'enseignement des arts plastiques repose essentiellement sur la mise en œuvre d'une pratique plastique réflexive au sein d'un groupe d'élèves se stimulant mutuellement mais s'emparant toujours de manière singulière de la situation pédagogique proposée par l'enseignant. Au travers de la pratique, l'élève se pose des questions, développe des compétences (disciplinaires et transversales) et renforce sa culture et ses connaissances. Les échanges, les coopérations, les confrontations mettent en exergue la pluralité des voies empruntées, ce qui constitue une condition nécessaire à la méthode de cet enseignement.

Comment, alors, mettre en œuvre un enseignement artistique à distance ?

Face à ces contraintes, il a été nécessaire de s'adapter, d'innover et de repenser cet enseignement. L'objectif premier a été de maintenir une pratique plastique régulière permettant aux élèves d'y trouver une échappatoire, une bouffée d'oxygène alors que les devoirs s'accumulaient au fil des jours. On sait également la portée expressive ou le caractère exutoire des pratiques artistiques, ce qui est non-négligeable compte tenu de ce contexte anxiogène. Tout au long du confinement, j'ai proposé aux élèves, du collège Charles de Gaulle de Bû, divers projets en veillant à ce que certains principes soient respectés (comme l'utilisation d'un matériel facilement accessible chez soi, par exemple).

Ce dossier, malgré sa forme synthétique, se veut être le témoin de l'engouement préservé des élèves pour la création artistique (parfois même partagé par toute la famille) et j'en veux pour preuve de la richesse des productions à suivre...

AB

Retrouvez toute l'actualité des arts plastiques
au collège sur le compte Instagram :
club.expo.bu

REACTIVER SES COMPETENCES [5^{ème}]

* L'utilisation du logiciel Photo Filtre, déjà utilisé en classe

SE METTRE EN SCENE [4^{ème}]

* Le portrait officiel et la représentation du pouvoir

PRENDRE LE TEMPS D'OBSERVER LE MONDE [6^{ème}]

* Par la fenêtre...

RECHERCHER LA POESIE DANS L'ESPACE NATUREL [3^{ème}]

* Au fond du jardin !

ETRE LE TEMOIN DE SON EPOQUE [6^{ème}]

* La portée symbolique de l'objet dans la nature morte

POSE/PAUSE INTROSPECTIVE [5^{ème}]

* Autoportrait expressif !

PORTER UN REGARD SINGULIER [4^{ème}]

* Représentation insolite du quotidien

REACTIVER SES COMPETENCES [5^{ème}]

* L'utilisation du logiciel Photo Filtre, déjà utilisé en classe

Les Robots IKEA

Présentation du sujet par un tuto vidéo :

<https://www.youtube.com/watch?v=eZccxY9enDQ&t=108s>

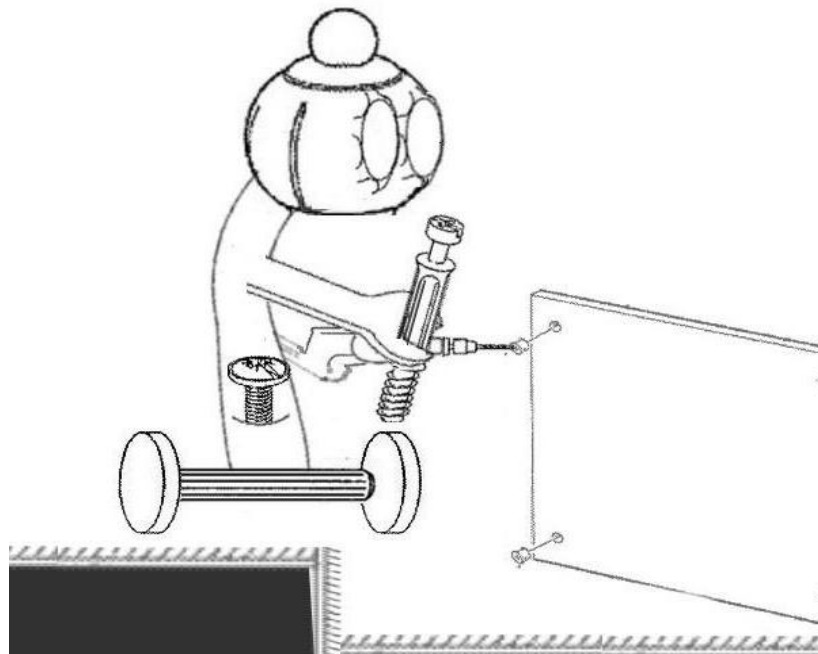
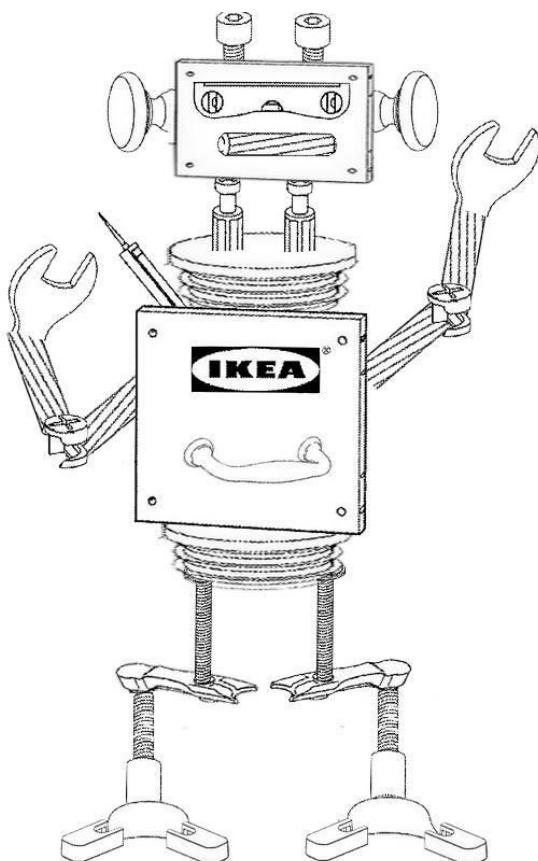
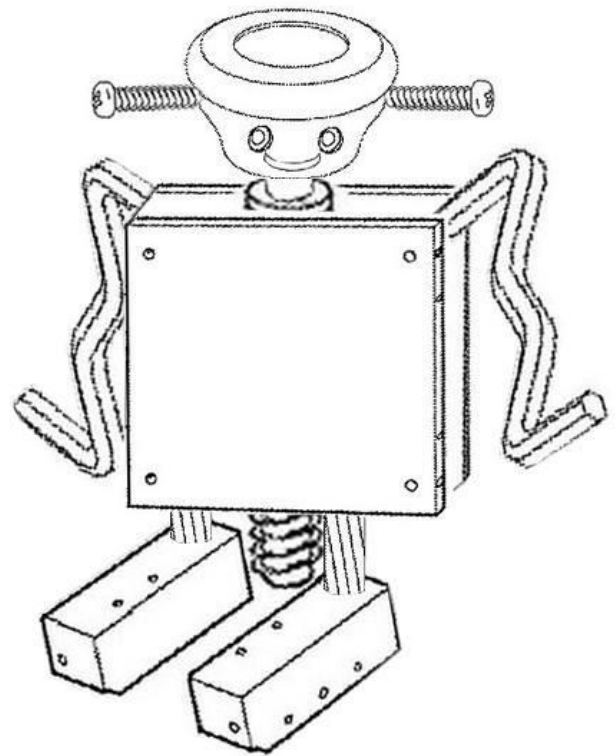
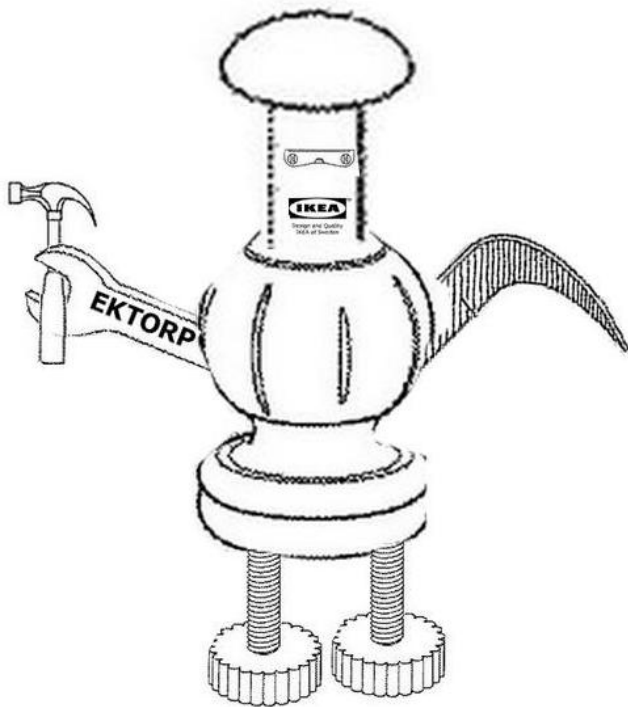
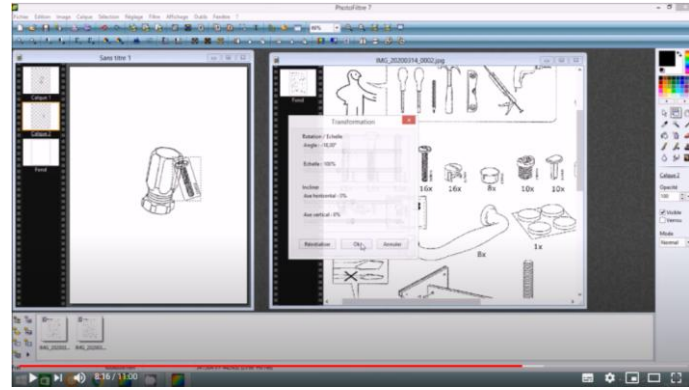

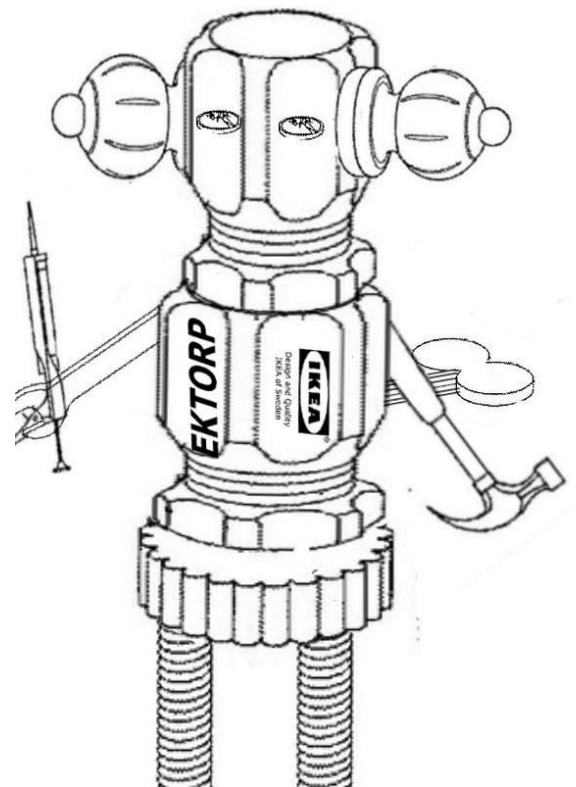
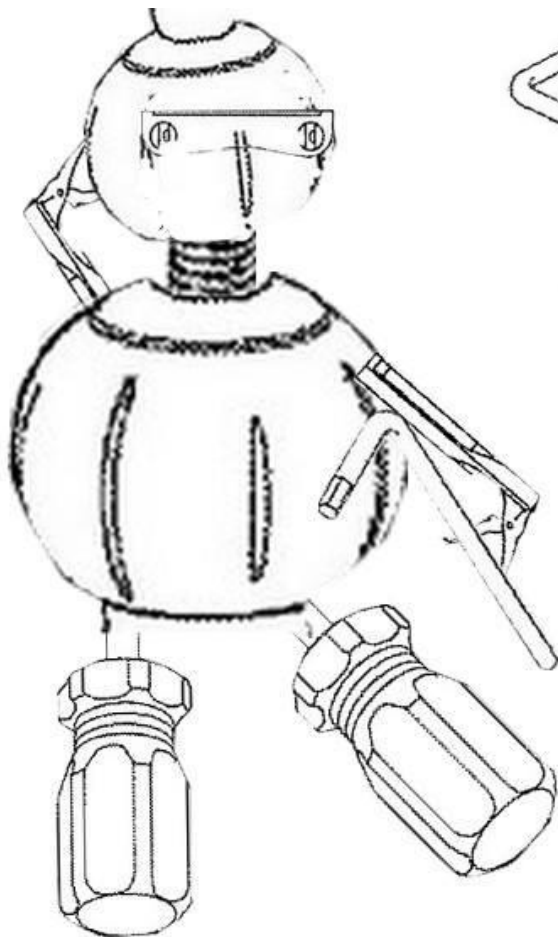
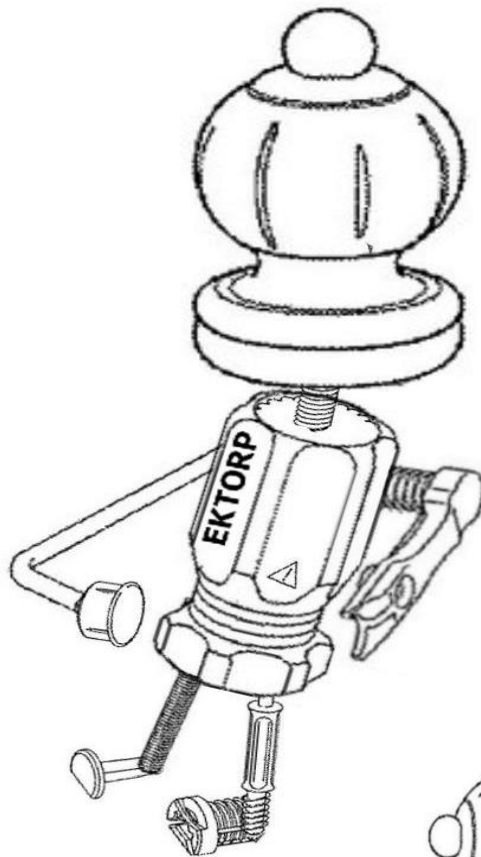
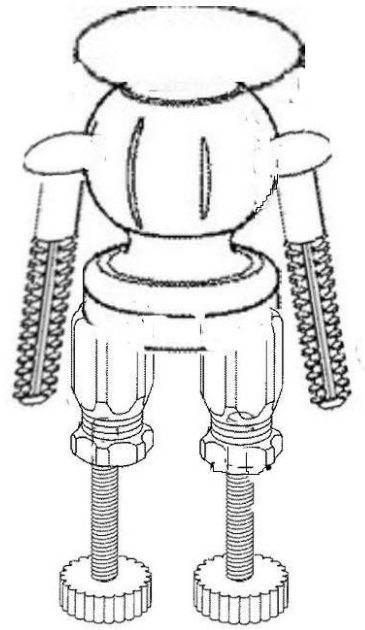
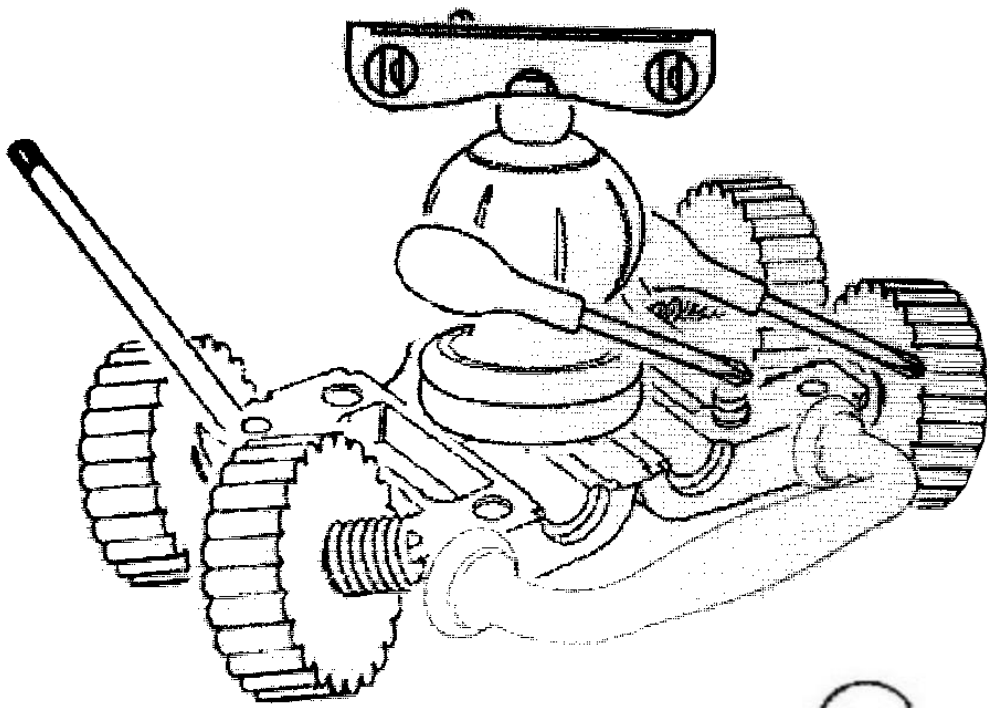

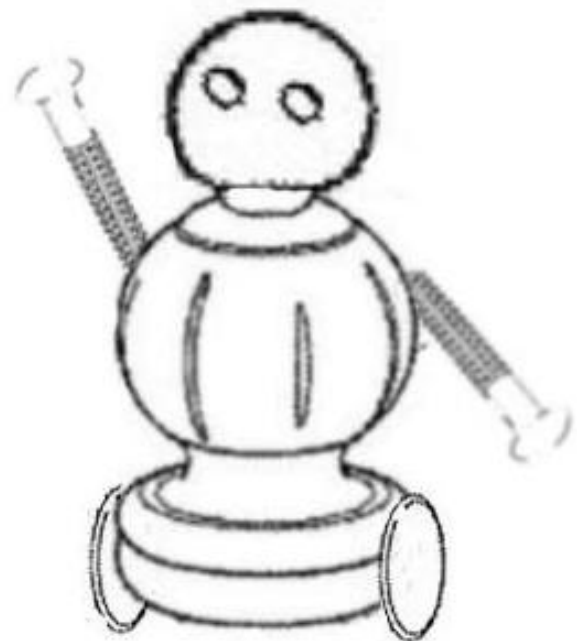
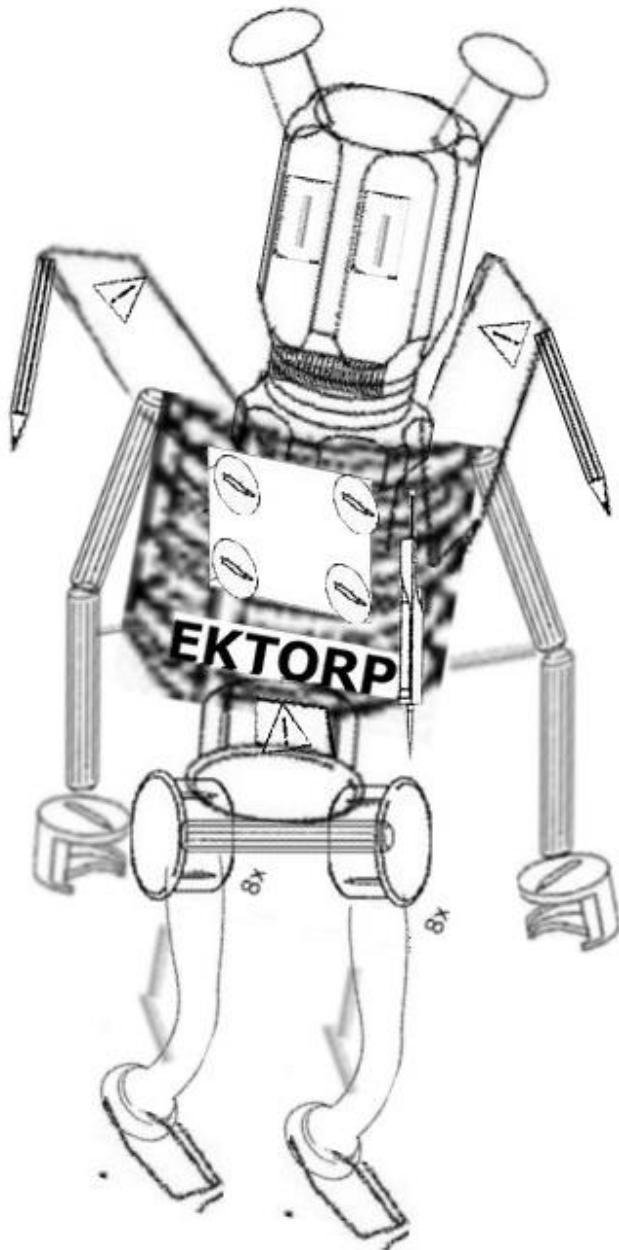
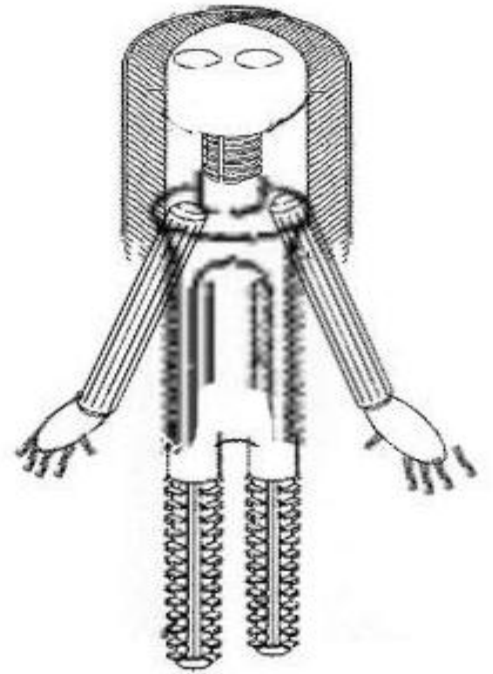
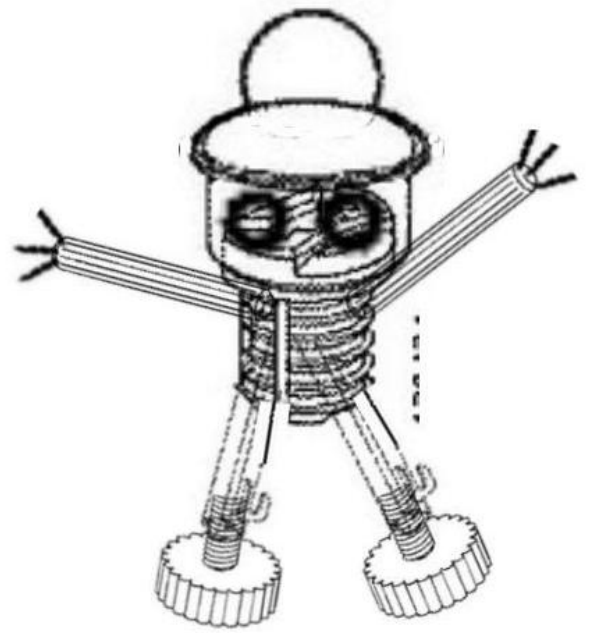
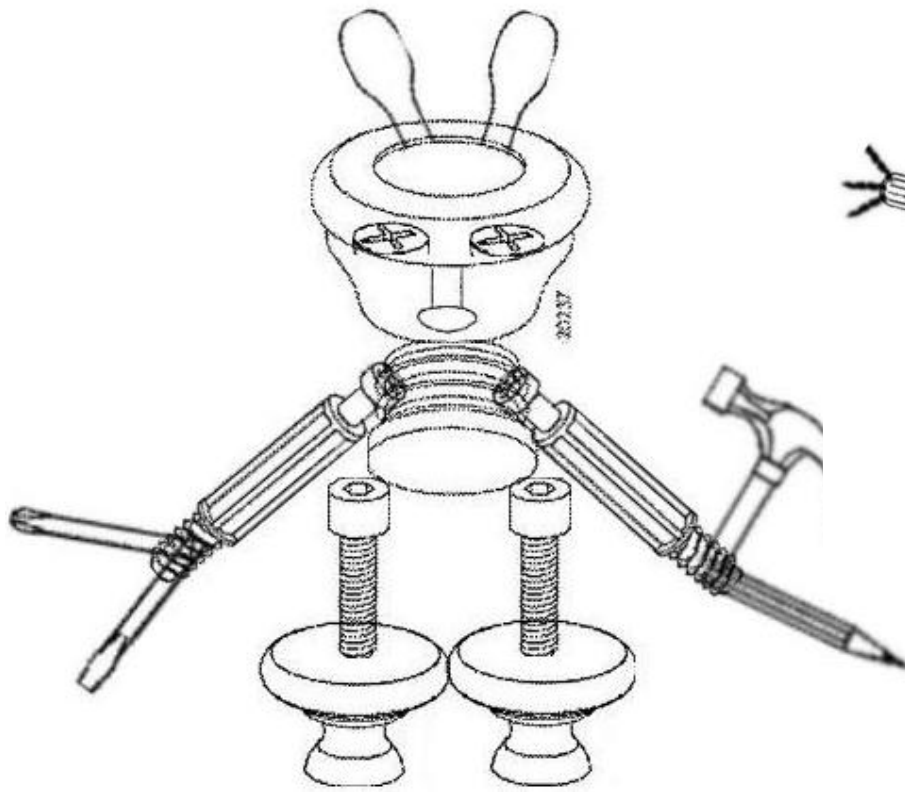

SE METTRE EN SCENE [4^{ème}]

* Le portrait officiel et la représentation du pouvoir

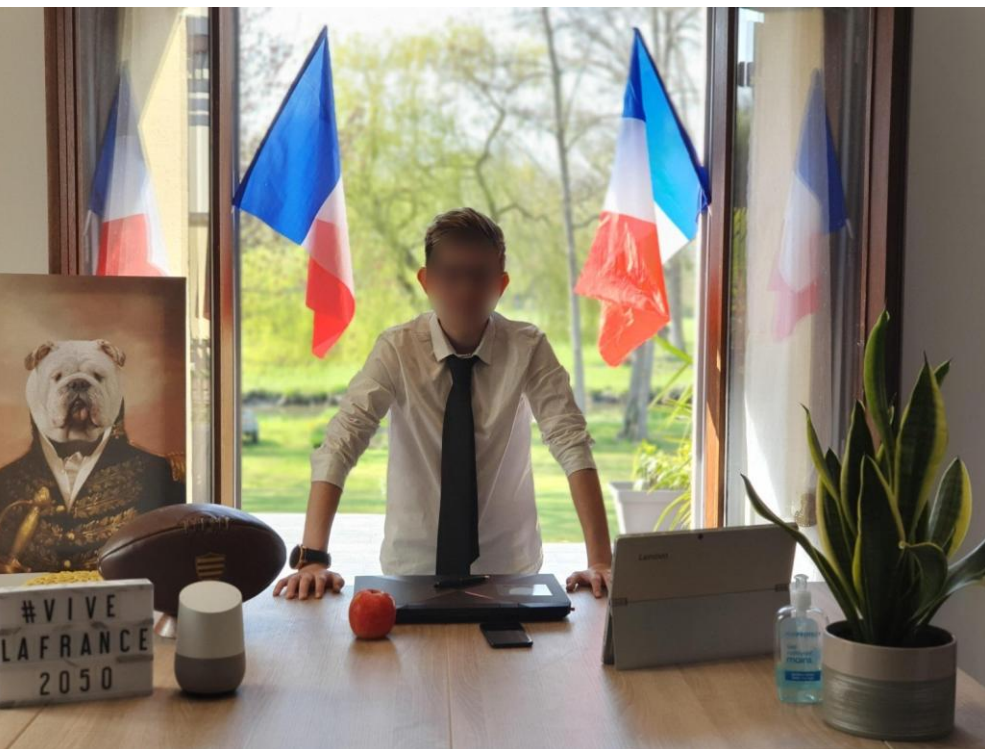

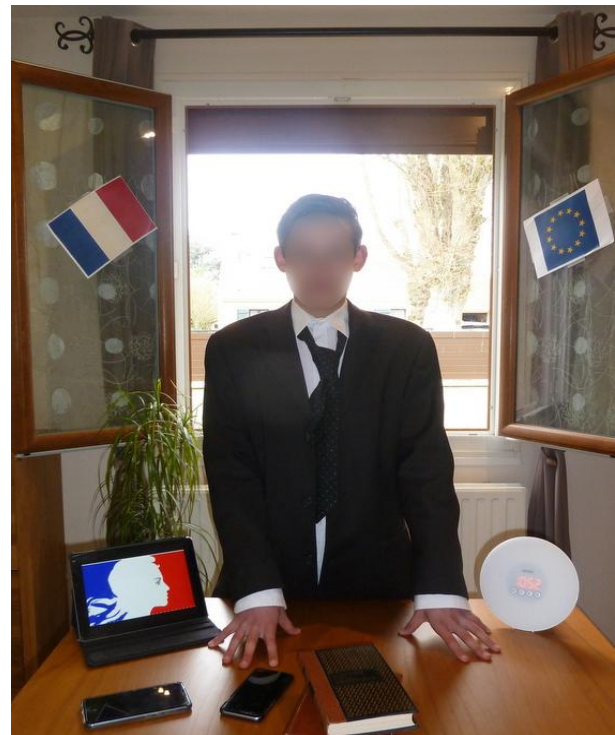
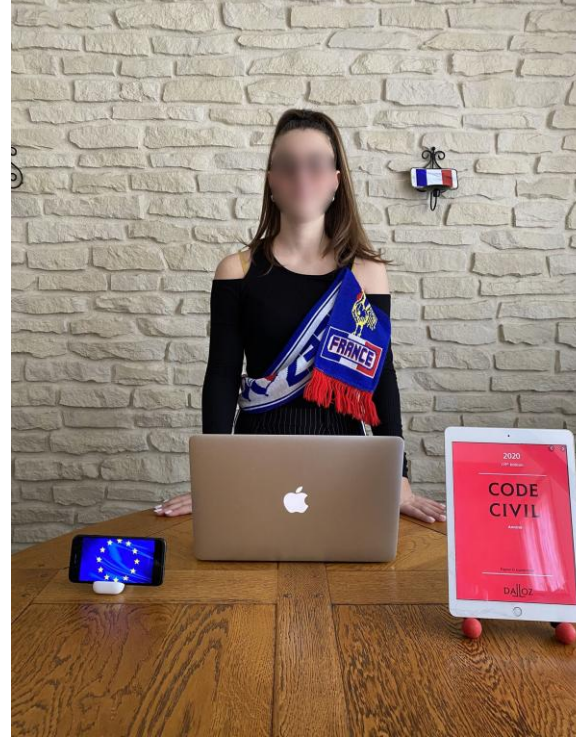



PRENDRE LE TEMPS D'OBSERVER LE MONDE ^[6^{ème}]

* Par la fenêtre...

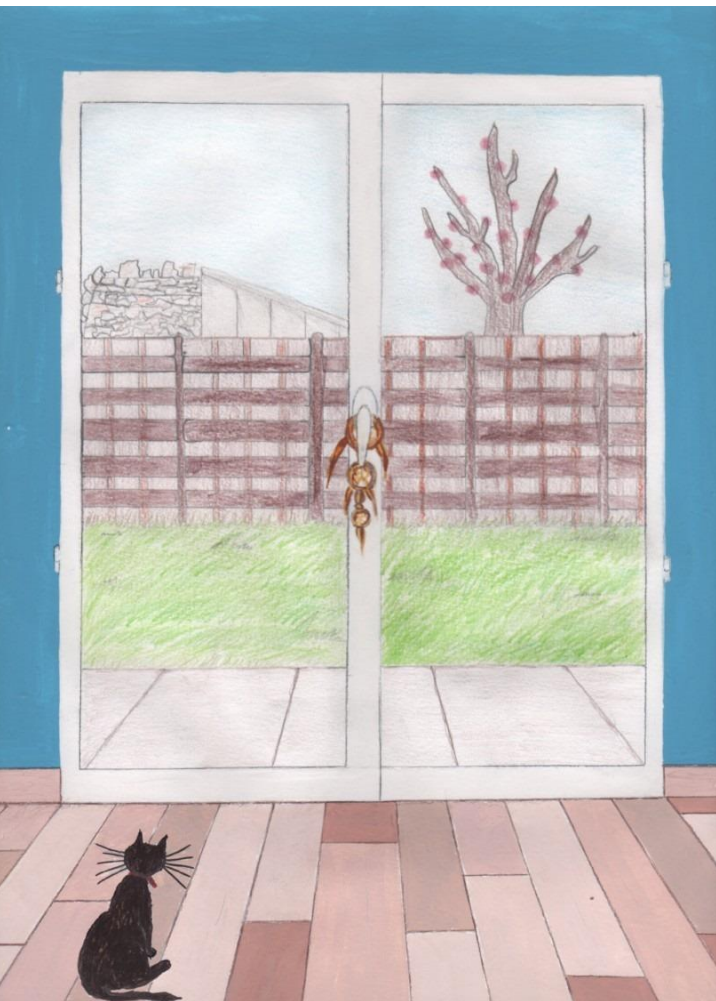

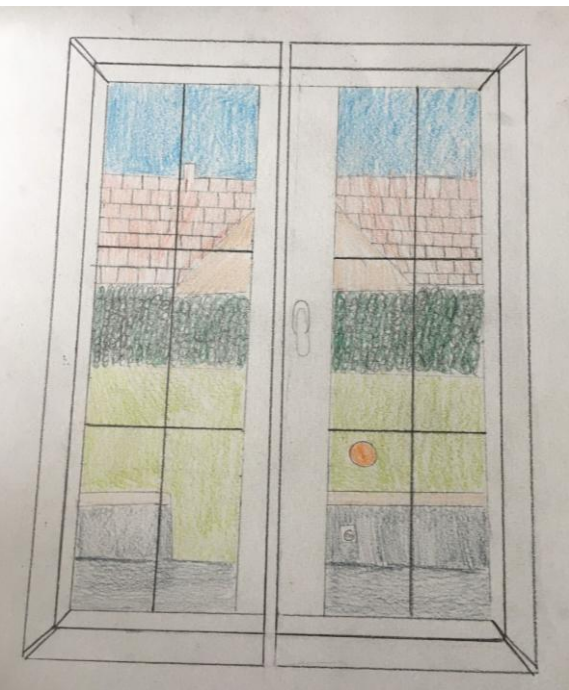



RECHERCHER LA POESIE DANS L'ESPACE NATUREL [3^{ème}]

* Au fond du jardin !

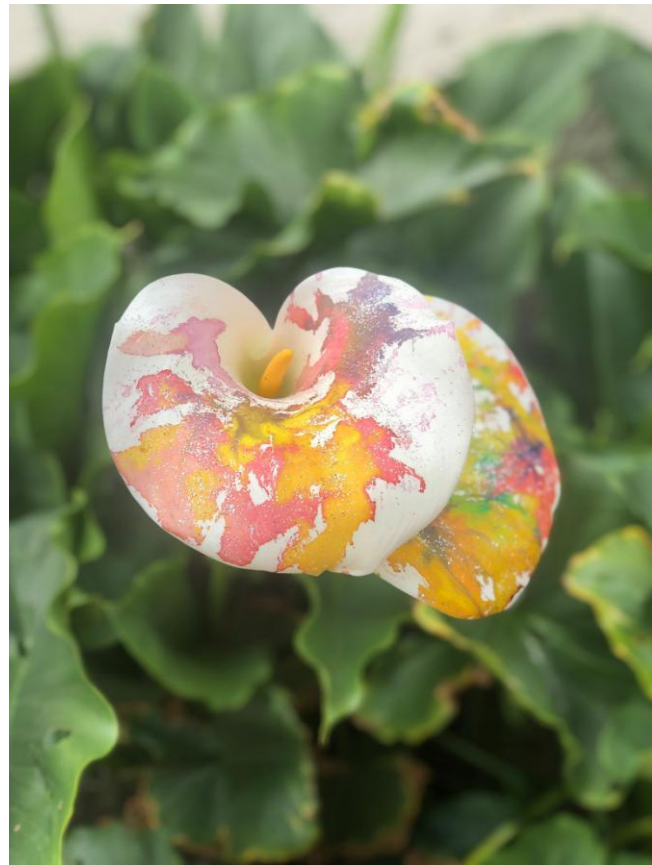

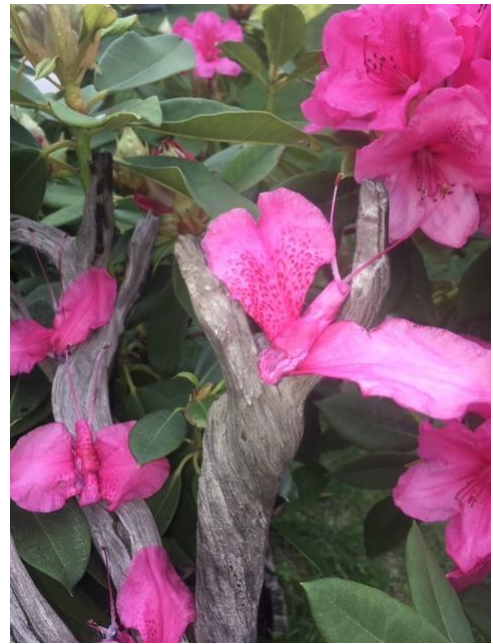



ETRE LE TEMOIN DE SON EPOQUE [6^{ème}]

* La portée symbolique de l'objet dans la nature morte





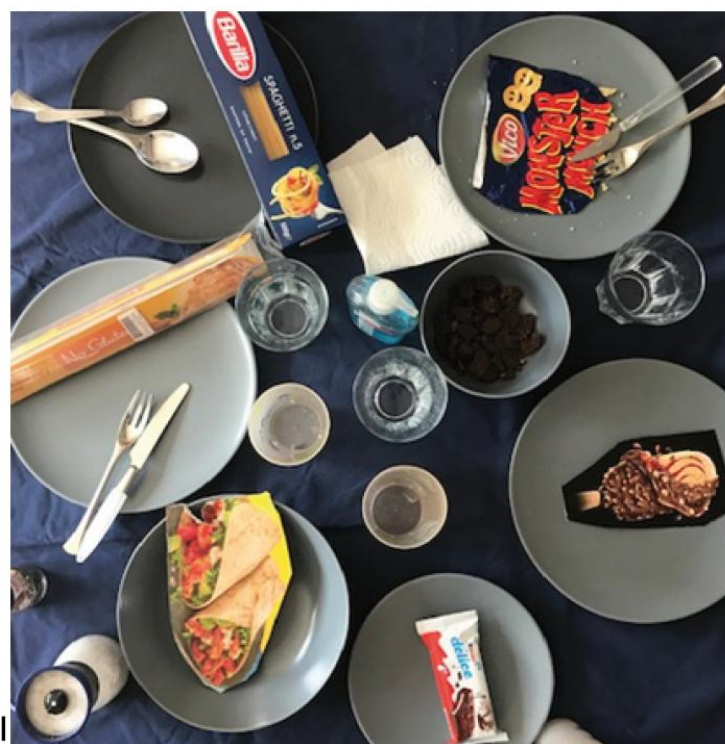

POSE/PAUSE INTROSPECTIVE (5^{ème})

* Autoportrait expressif !

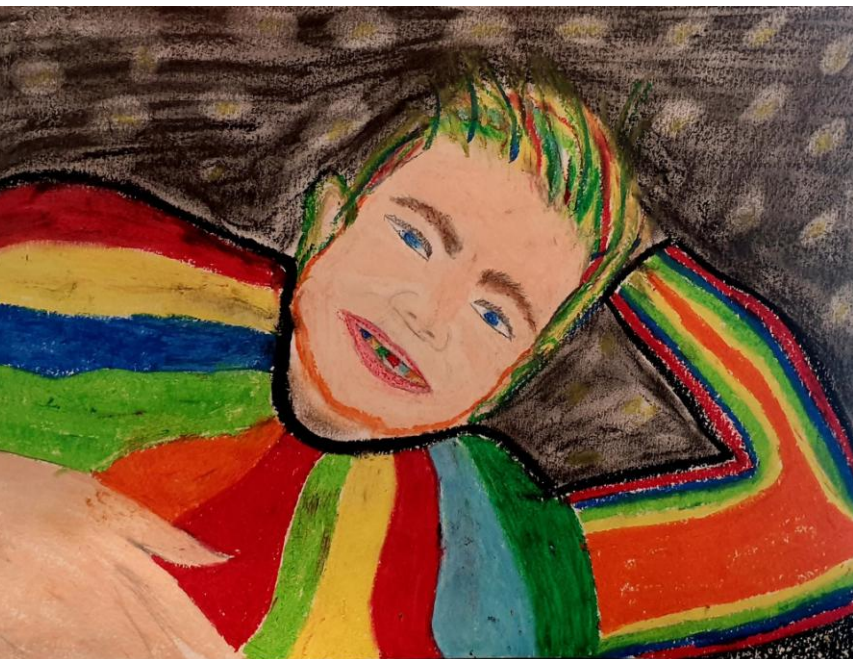





PORTER UN REGARD SINGULIER [4^{ème}]

* Représentation insolite du quotidien





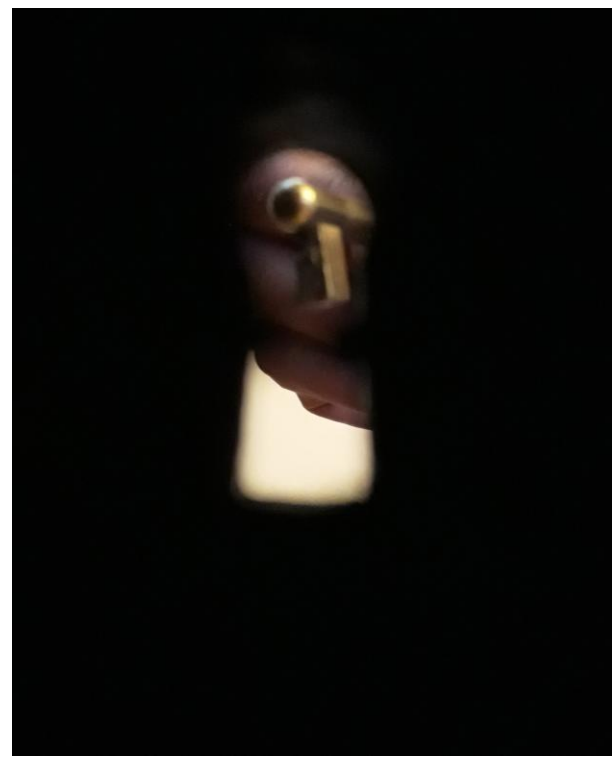

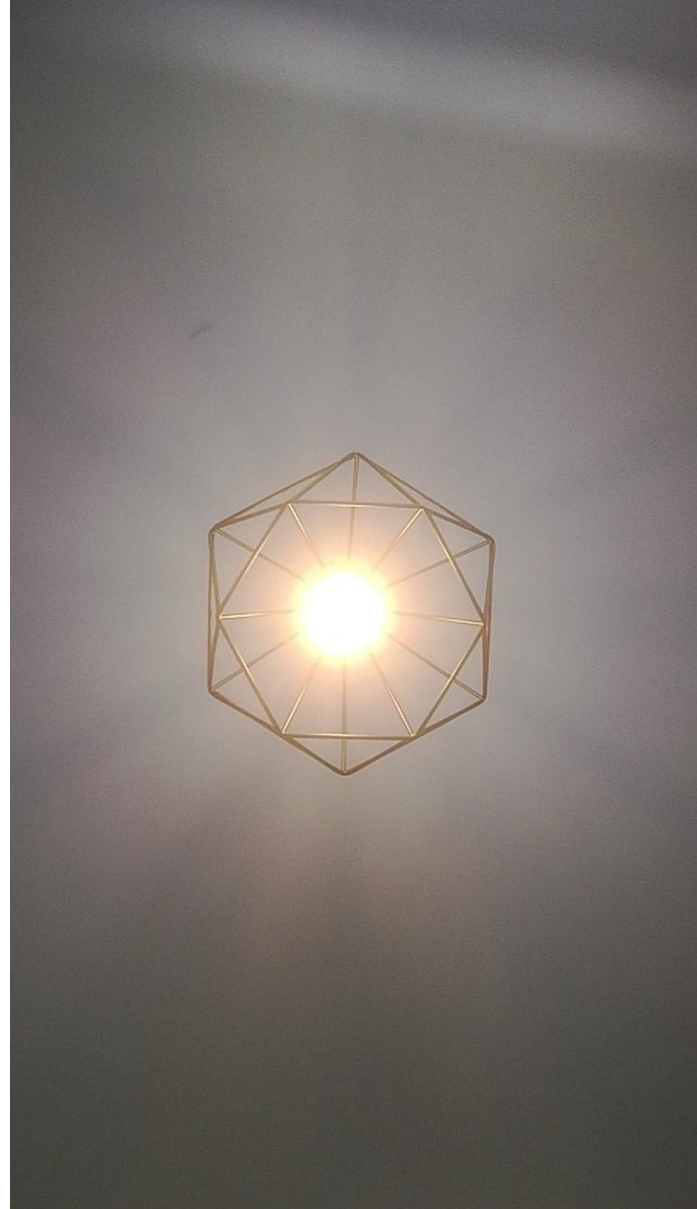

© Dossier réalisé par M. Bruneau
– Professeur d'Arts Plastiques